

## WARNING

Before use please remove the LED Tape from its bag and allow the odour to dissipate in an unused room or outdoor building.  
Wash Hands after handling.

This product uses High Brightness LEDs. Direct viewing of the SMD LEDs at close range should be avoided.

Keep product away from children.

Clean the LED Tape with damp a tissue only.

Litewave LTD. Will not accept responsibility for any other issues arising from improper use or fitting of this product where such matters are beyond our control.

Having highlighted a number of safety issues and warnings in this installation guide Litewave LTD. will accept NO responsibility for issues arising from any failure to comply with these instructions and recommendations.

Although the product is tested after manufacturing, it is highly advisable to remove the LED Tape if on a reel and test the Flexible LED Tape before cutting or fixing in place to make sure it has not been physically damaged in transit, and that it is the correct colour.

Connect the Black (+) wire to the positive (+) wire of a 12 Volt DC Switchmode Power Supply\* (a 9v PP3 will also work for testing), then separately connect the 3 remaining coloured wires to the negative (-) wire of the power supply (or battery) to confirm that each of the primary colours – Red, Green, and Blue are all working. Ensure that all of the LEDs are fully lit, but **AVOID VIEWING THE LEDS DIRECTLY**

Next identify the location where the Tape is to be fixed. Do not fix the Tape where it will be permanently wet. With suitable insulation covering any exposed wired connections the tape will not be damaged by moderate amounts of atmospheric moisture or the occasional water spray. If the tape is powered-up while submerged in water there is a risk of short-circuit and possibly even fire in the long term. Equally, do not affix the tape directly to a metal surface where there is a risk of creating a short-circuit on the back of the tape if accidentally perforated.

Once the location for the Tape has been decided upon simply remove the 3M Adhesive backing strip and carefully lay the Tape in place working from one end to the other ensuring there are no raised sections. Using a lint-free cloth gently press between the LEDs on the tape to remove any air bubbles and activate the adhesive, however, make sure you do not press directly on the LEDs themselves as this could damage them.

## Wiring

The 4 wires from the LED Tape can be extended if necessary by using any low-voltage 4-Core cable with a current rating of 3 Amps or greater. With long cable runs the use of a cable with a higher current rating will ensure minimal voltage-drop in the wiring which could otherwise affect the colour rendering. **1.5M of RGB Tape is the maximum recommended length** for a continuous run (spur) **or joined lengths** of 60LED/M RGB LED Tape otherwise colours may not appear uniform along the entire length and the Tape may be overloaded. If longer runs are required, and the power supply has adequate capacity, additional lengths should be wired back directly to the supply or driver forming separate spurs. The tape itself is unsuited to carrying more than 3 Amps so do not extend it with excess lengths or other types of current load.

If a power supply having a significantly greater current capacity than the current requirement for the LED Tape is to be used then a safety fuse will be required along the positive input wire to the product. This is to prevent excess current flowing in the supply wiring or the LED Tape under fault conditions such as accidental damage. Such a fuse must be located as near to the supply or driver to protect the installation wiring and shall have a current rating just higher than the load anticipated in the spur. Each additional Spur will require its own separate fuse.

If linking the Flexidriver to a ZAP+ or ZEN Controller, the cable or wire between the Controller and the Flexidriver should be rated according to the total load being powered, see cable and fuse ratings.

**Note** that a fuse may only be omitted from the low voltage side if the power supply provides its own overload protection and is unable to significantly exceed the maximum rating of the wiring and LED product before it trips.

**If hard-wiring the input of the Power Supply to the AC mains it is essential to use a fused wall switch or outlet. The fuse on the mains side should be 3A or less. Only a qualified electrician should hard-wire the Mains PSU.**

**Power Supplies should be installed in a dry location.**

**Wiring without the ICELED Flexidriver.** The best way for basic control (although only 7 colours will be available) is to use a switch along each of the coloured wires. Each switch in turn should be connected to the negative of the power supply. The remaining (+) wire from the LED Tape connects to the (+) positive 12 Volts on the Power Supply via a Fuse.

However we would advise using the ICELED Flexidriver which will generate a range of over 2 million colours by varying the power to each of the 3 colours. For even further control use the Flexidriver in conjunction with an ICELED ZAP+ or ZEN Controller.

**Wiring the LED Tape to the Flexidriver** Connect the four colour coded wires to the corresponding labels on the Flexidriver as shown below, make sure all the screws are tightened securely onto the wires – being careful not to trap the insulation under the screw as this could cause a poor connection. The connector fitted to the RGB Tape should be removed enabling connection as shown below. The remaining wire should be connected to the terminal labeled "12VDC". Only one end of the RGB Tape needs to be connected to the Flexidriver. **NOTE:** For clarity the + wire on the RGB LED Tape is shown as black.

There are 4 coloured wires on the RGB Tape, the main colours; Blue, Green, and Red connect to the Terminals with the corresponding labels, the remaining wire connects to the "12vdc" terminal.

We highly recommend using a 2A Fuse (Fast Blow) for each Spur of LED Tape as shown below. A fuse rated for the total load should also be used on the input side to the Flexidriver, or input side to ZAP+ or ZEN Controller if used.

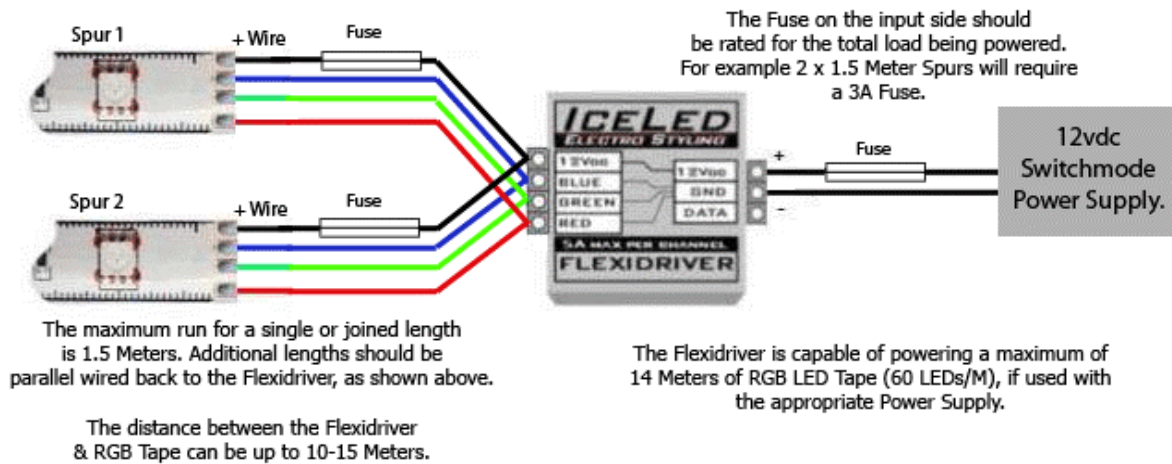

Next you will need to connect the 12vdc power supply to the Flexidriver.

The positive (+) wire should be connected to the "12VDC" label on the Flexidriver, the remaining wire connects to the "GND" label. Switch on the power to the power supply, the Tape should now light up if it does not immediately switch off power and re-check all fuses and connections.

We do not advise using the product in a vehicle, you fit to a vehicle at your own risk.

**PLEASE NOTE:** If using in a vehicle or on a vehicle battery **it is essential** to use an in-line fuse along the + input wire to the Flexidriver or Controllers (if used) as well as a fuse for each spur, if unsure consult a qualified vehicle electrician.

Follow the cable ratings on page 4 for the appropriate amperage fuse. If a ZEN or ZAP Controller is fitted prior to the Flexidriver the fuse should be on the input to the controller.

## Cutting and connecting the Tape

**Once cut the LED Tape will no longer be Splash-proof. If cut or trimmed it should not be installed near to sources of water or areas where it is likely to come into contact with water.**

Although we advise against cutting and reconnecting the LED Tape because this will affect your warranty, we have provided a brief guide of how to cut and join the tape below. **NOTE: When soldering always do so in a well ventilated area and wear a mask.**

Whether trimming to length or cutting the LED Tape into shorter lengths for reconnecting you need to cut the tape along the line with the 4 solder pads on either side of the cut.

Carefully remove 4-5mm of the silicone and resin taking care not to cut into the tracks of the pcb, this can be done with a sharp stanley knife (always use sharp tools carefully). Make sure you have removed all of the silicone and resin on and around the solder pads before soldering. Securing the LED Tape before soldering will make the task easier.



Be careful when soldering that you do not overheat the pads as this heat can damage the pad and the LEDs, a small dab of flux paste helps with a fast solder connection. **Make sure the wire you use is rated for load.**

Apply a small blob of solder to each copper solder pad. Before soldering the wire to the pads it is best to apply a small amount of solder to each of the wires to tin the wires this will prevent the wires from becoming frayed and causing a short-circuit.

A different coloured wire such as black should be soldered to the positive (+) pad. The + pad is identified on the PCB with the "+12V" marking. Then solder the **blue, red, and green** wires in that order to the remaining pads as shown in the diagram. Be careful when soldering that you do not overheat the pads as this heat can damage the pad and the LEDs, a small dab of flux paste helps with a fast solder connection. Ensure that the soldered connections are clean and there are no wires touching which could cause a short circuit.

The soldered joints **must** be insulated to prevent accidental short-circuits. End caps are supplied for terminating trimmed lengths, these can be partially filled with Hot Glue prior to fitting the end cap over the end of the LED Tape, carefully squeeze out any excess glue. Alternatively adhesive lined heat shrink can be used (12 to 13mmmm Heat Shrink with 3:1 Shrink Ratio). If using heat shrink cut a length around 35-40mm, place about 14mm of heat shrink over the end of the LED Tape then heat gently with a heat gun until the shrink forms tightly around the LED Tape, then crimp the end with a pair of pliers forming a closed end while the heat shrink is still very warm, cut off the excess heat shrink. Adhesive lined heat shrink can also be used for insulating wired connections as shown above.

To get around corners, cut the LED Tape to the nearest 50mm then use connecting wire (rated for the load) to take the voltage around the corner to another length of LED Tape. 1.5 Meters is the maximum total length that should be connected together. Again any connections that are made should be insulated with adhesive lined heat shrink.

RGB LED Tape with 60 LEDs Per Meter

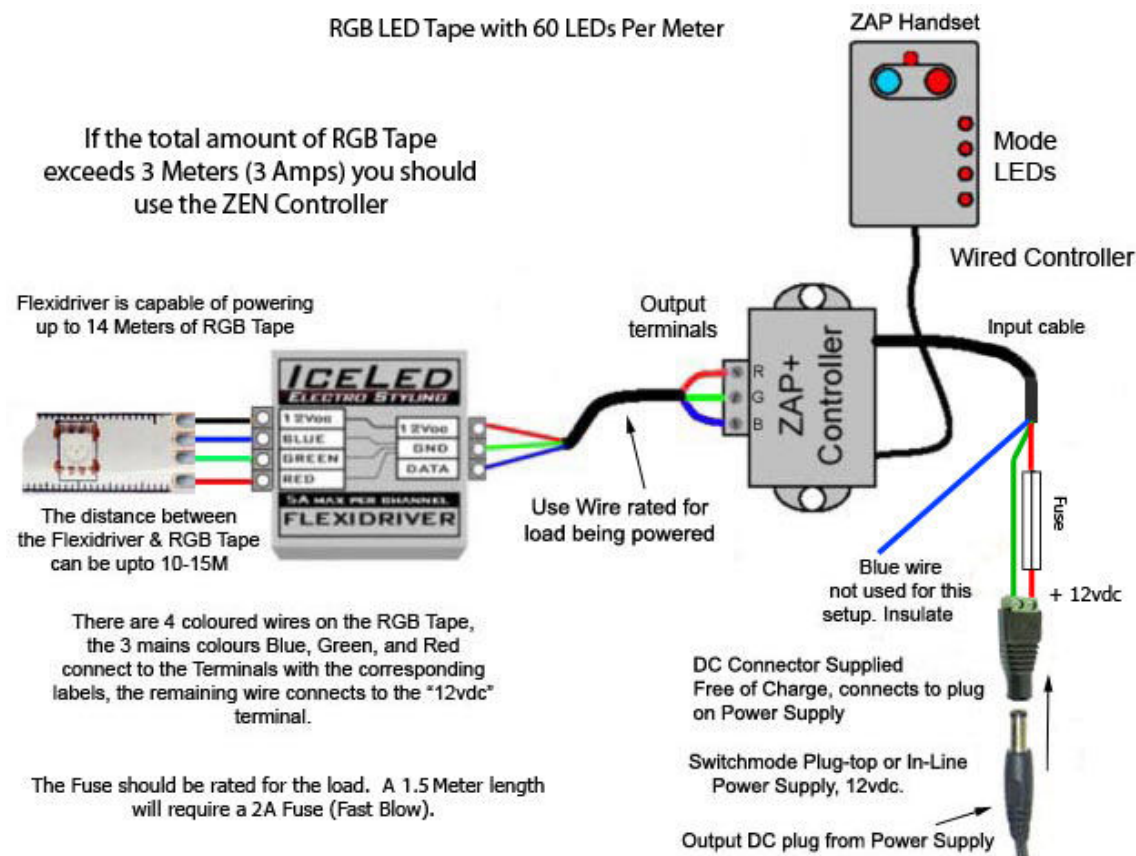

### Connection to a ZAP+ Controller:

**NOTE:** The maximum length of RGB Tape that can be connected using this method is 3 Meters due to the current handling capacity of ZAP+.

To power the maximum amount (3M) of Tape a 3.5A Power Supply is required.

## Connection to a ZEN Controller:

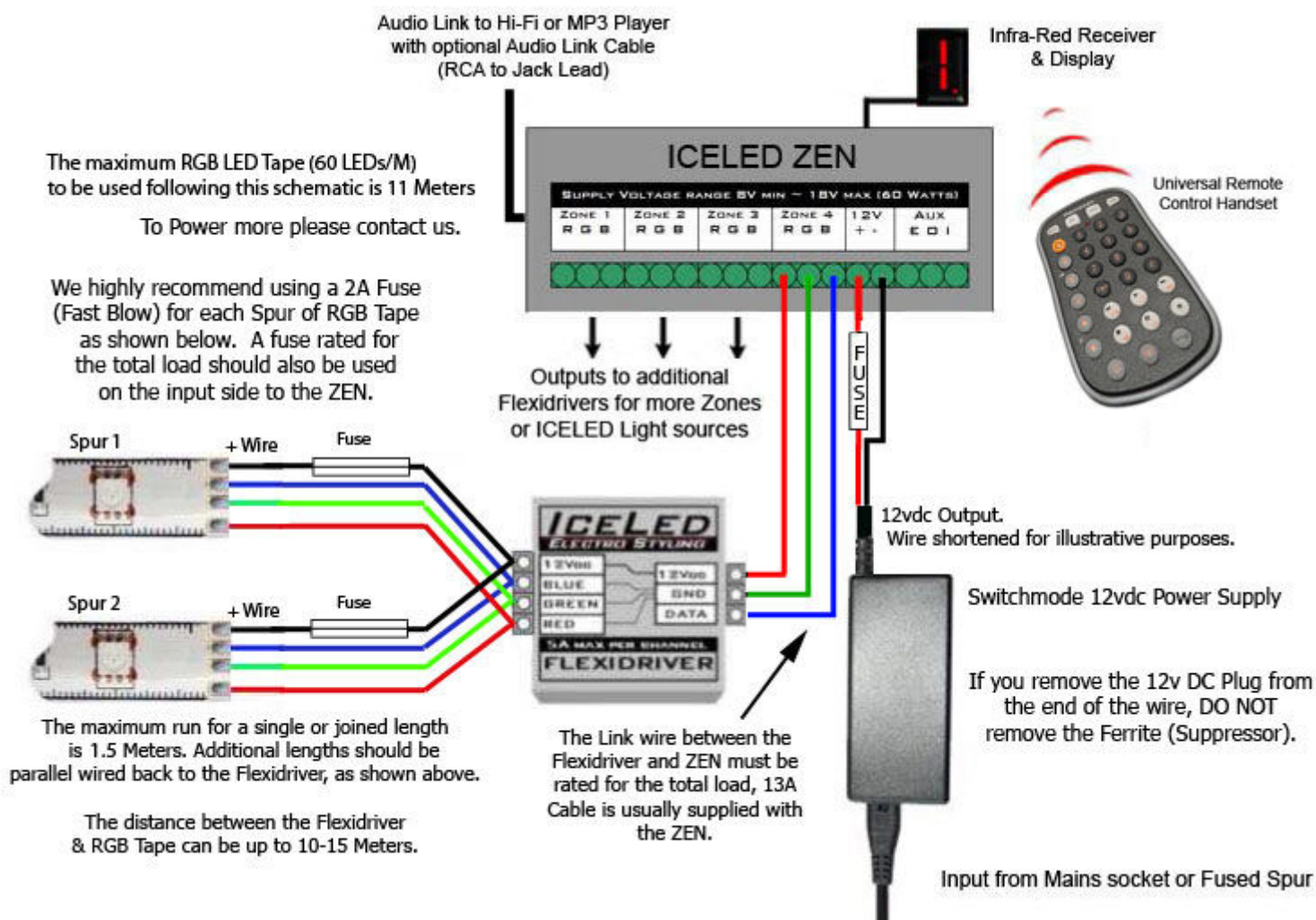

## Warranty

This product is warranted from manufacturing defect only. This warranty is valid for 1 year from the date of purchase. This warranty does not apply to damage caused by user installation or normal wear and tear. Cutting the tape will automatically void your warranty, so do so carefully. If a segment becomes faulty only that part can be replaced under warranty once cut.

Litewave LTD. gives no warranty against damage to any surface due to applying or removing this product. Please follow instructions and heed all warnings carefully.

## Specifications

Nominal supply voltage:	12 Volts DC
Viewing Angle:	120 Degrees
Maximum current drain:	Approx. 1.5 Amps (1500ma) per Meter
LED Type:	SMD 5050 (60 LEDs per Meter)
Light Output:	360 Lumens/m
Durability:	Lightly Splashproof (If Tape is cut connections need to be resealed).



## Cable and Fuse (Fast Blow) rating:

1.5 Meters = 2A

3 Meters = 3A

6 Meters = 6A

8 Meters = 8A

10 Meters = 10A

Flexible **SILICONE** RGB LED Tape – 60 LEDs Per Meter (20/03/12)



## Resources

To see the full Litewave product range visit <http://www.litewave.co.uk>

**Important: Installation by qualified electrician recommended.**

### **IMPORTANT Safety Information:**

- Keep away from children, this is not a toy.
- DO NOT place or fit the LED Tape near sources of heat or naked flames. Do not install on flammable material.
- Not recommended for use in direct sunlight or in extreme temperatures.
- Maximum length of Tape is 1.5 Meters do not exceed or extend.
- The Tape should not be installed around tight or angled bends as it may cause the resin to crack. It must be installed in a straight line. DO NOT curl or twist the LED Tape whilst power is on. The LED Tape can be bent on it's flat side but should not be flexed sideways.
- The LED Tape should be removed from the reel before powering.
- Soldered connections should not cause a short across the tracks. Connections should be sealed with hot glue or silicone and heat shrink or adhesive lined heat shrink.
- Assembly or connections must not damage or destroy conducting paths on the circuit board. The LED Tape itself and all its components should not be mechanically stressed.
- Installation of LED Tape (with power supplies) needs to be made with regard to all applicable electrical and safety standards.
- We advise a qualified electrician perform entire installation.
- Correct electrical polarity needs to be observed. Wrong polarity may damage the LED Tape.
- Parallel connection is highly recommended as safe electrical operation mode.
- Serial connection is not recommended. Unbalanced voltage drop can cause hazardous overload and damage the LED Tape.
- Please ensure that the power supply is of sufficient power to operate the total load.
- \* Only power the LED Tape with a 12vdc Switchmode Power Supply (constant voltage). Do not use a constant current Power Supply. Do not exceed the load of the Power Supply. The Power Supply should conform to Class 2 and SELV standards.
- Fixing to conductive or metal surfaces is not recommended. If fixing on metallic or otherwise conductive surfaces, there should be an electrical insulator between LED Tape and the mounting surface to prevent possible short-circuit.
- All LEDs are static sensitive.
- Damaged by corrosion will not be honored as a materials defect claim. It is the user's responsibility to provide suitable protection against corrosive agents such as moisture and condensation and other harmful elements.
- Identify Positive (+) and negative (-) outputs of the Power Supply by using a multimeter.
- Electrical Connections and joints should be in a dry area unless adequately sealed.

LITEWAVE LTD. MAKES NO WARRANTY, EITHER EXPRESSED OR IMPLIED, INCLUDING BUT NOT LIMITED TO ANY IMPLIED WARRANTIES OF MERCHANTABILITY OR FITNESS FOR A PARTICULAR PURPOSE, REGARDING THESE LITEWAVE LTD. MAKES PRODUCTS AVAILABLE SOLELY ON AN "AS-IS" BASIS. IN NO EVENT SHALL LITEWAVE LTD. BE LIABLE TO ANYONE FOR SPECIAL, COLLATERAL, INCIDENTAL, OR CONSEQUENTIAL DAMAGES IN CONNECTION WITH OR ARISING OUT OF PURCHASE OR USE OF LITEWAVE PRODUCTS. THE SOLE AND EXCLUSIVE LIABILITY TO LITEWAVE LTD, REGARDLESS OF THE FORM OF ACTION, SHALL NOT EXCEED THE PURCHASE PRICE OF THE LITEWAVE PRODUCT DESCRIBED HERE IN.

### **Environmental Information**



At the end of this product's usable life it should be disposed of according to WEEE regulations, which means it should be taken to your local municipal site for safe disposal/recycling.